

# PHILCO RADIO-PHONOGRAPH MODELS 51-1731 and 51-1732

## SPECIFICATIONS

CABINET .....	Wood console, mahogany finish
CIRCUIT .....	8-tube superheterodyne
FREQUENCY RANGES	
Standard broadcast .....	540—1630 kc.
FM .....	88—108 mc.
AUDIO OUTPUT	
Model 51-1731 .....	3.0 watts
Model 51-1732 .....	5.0 watts
OPERATING VOLTAGE .....	117 volts, 60 cycles, a.c.
POWER CONSUMPTION	
Radio .....	110 watts
Phonograph .....	125 watts
AERIALS .....	Built-in broadcast loop; FM line-cord aerial; provision for connection of external aerials.
INTERMEDIATE FREQUENCIES	
AM .....	455 kc.
FM .....	9.1 mc.
PHILCO TUBES (7) .....	6AU6 r-f ampl., 7F8/S osc.-mixer-phono preamp., 6BA6 1st i-f ampl., 6AU6 2nd i-f ampl., 6V8 det.-a.v.c.-1st audio, 6W6GT (51-1731) or 6Y6GT (51-1732) output, 5A24 rectifier.
RECORD PLAYER .....	Philco Model M-22 All-Speed Automatic Record Changer (For service information, refer to the Record Changer section of this Yearbook.)

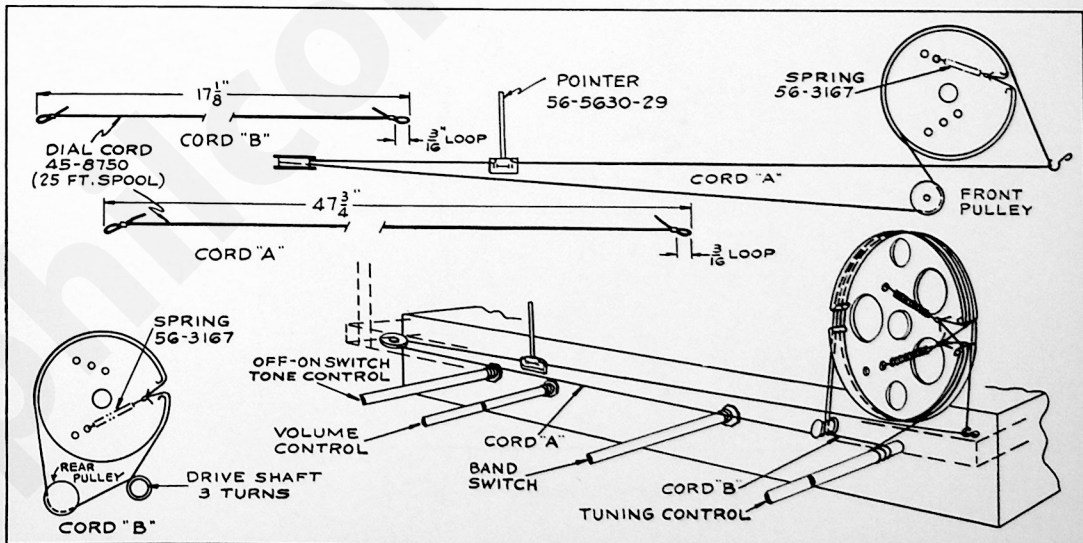

Figure 1. Drive-Cord Installation Details

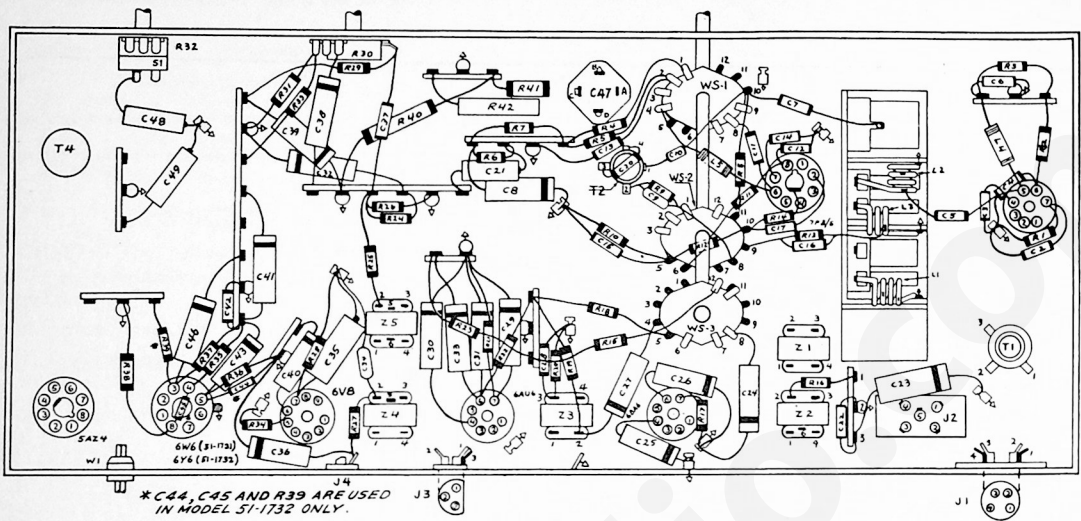

Figure 2. Symbolized Chassis, Showing Parts Placement

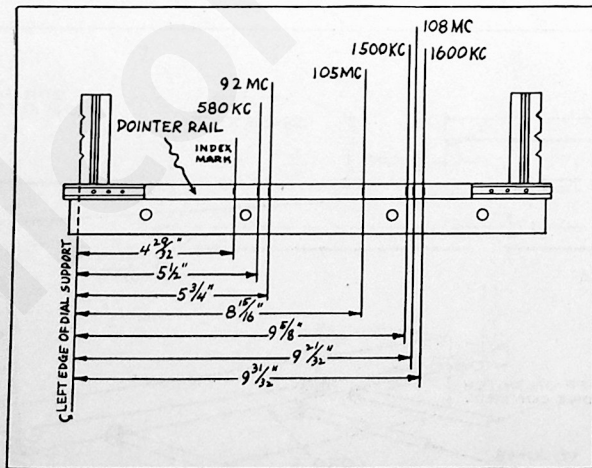
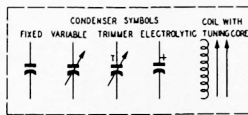
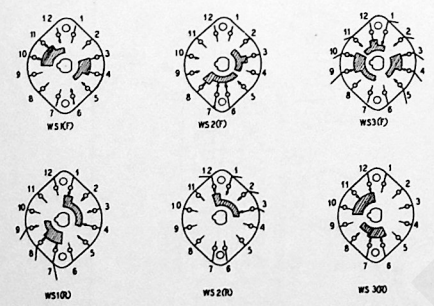
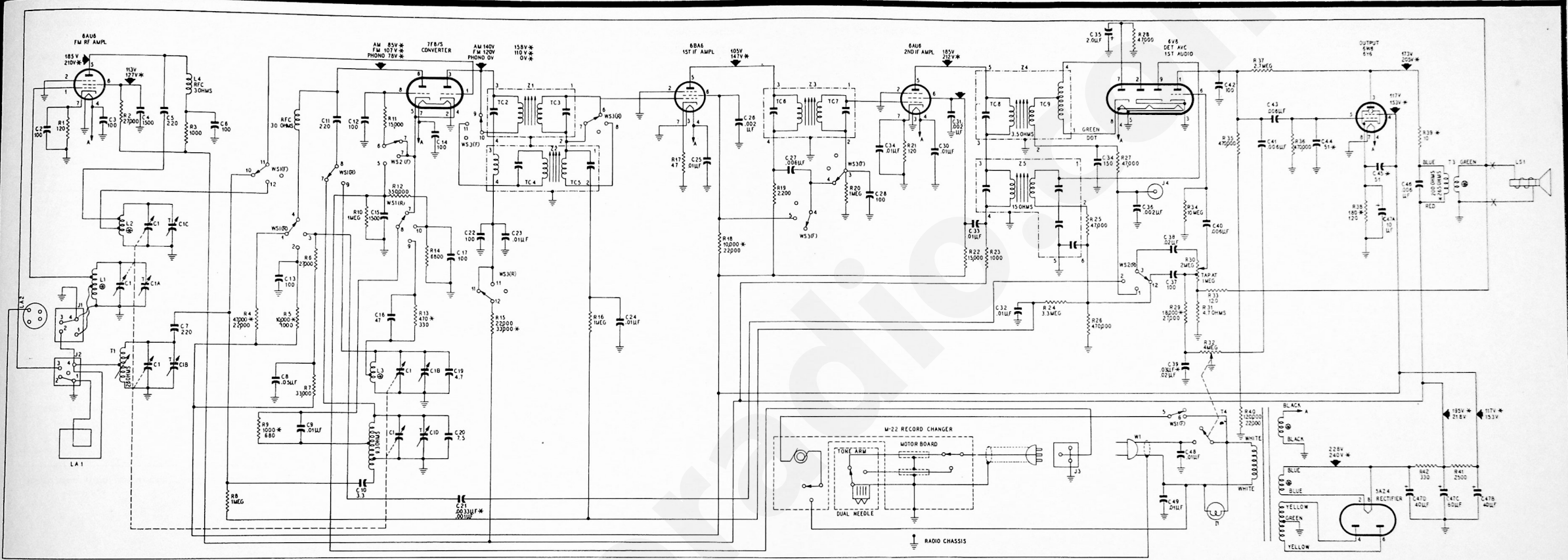

Figure 3. Dial-Backplate Calibration Measurements

# REPLACEMENT PARTS LIST

NOTE: Part numbers identified by an asterisk (\*) are general replacement items. These numbers may not be identical with those on factory parts; also, the electrical values of some replacement items may differ from the values indicated in the schematic diagram and parts list. The values substituted in any case are so chosen that the operation of the radio will be either unchanged or improved. When ordering replacements, use only the "Service Part No."

Reference Symbol	Description	Service Part No.	Reference Symbol	Description	Service Part No.
C1	Condenser, tuning gang, five section	31-2756-2	C46	Condenser, tone compensation, .006 $\mu$ f.	45-3500-7*
C2	Condenser, cathode by-pass, 100 $\mu$ f.	62-110001001	C47	Condenser, electrolytic, 4 section,	
C3	Condenser, filament by-pass, 100 $\mu$ f.	62-110001001		Model 51-1731	30-2570-63
C4	Condenser, screen by-pass, 1500 $\mu$ f.	62-215001001		Model 51-1732	30-2570-64
C5	Condenser, d-c blocking, 220 $\mu$ f.	62-122001001	C47A	Condenser, cathode by-pass, 10 $\mu$ f.,	
C6	Condenser, plate decoupling, 100 $\mu$ f.	62-110001001		25wv	Part of C47
C7	Condenser, d-c blocking, 220 $\mu$ f.	62-122001001	C47B	Condenser, filter, 40 $\mu$ f.,	
C8	Condenser, plate decoupling (Phono),			Model 51-1731—300wv	Part of C47
	.05 $\mu$ f.	61-0122*		Model 51-1732—350wv	Part of C47
C9	Condenser, d-c blocking, .01 $\mu$ f. mica	30-1226-10	C47C	Condenser, filter, 60 $\mu$ f.,	
C10	Condenser, neutralization, 3.3 $\mu$ f.			Model 51-1731—350wv	Part of C47
C11	Condenser, d-c blocking, 220 $\mu$ f.	62-122001001		Model 51-1732—400wv	Part of C47
C12	Condenser, grid by-pass, 100 $\mu$ f.	62-110001001	C47D	Condenser, filter, 40 $\mu$ f.,	
C13	Condenser, plate decoupling (FM),			Model 51-1731—350wv	Part of C47
	100 $\mu$ f.	62-110001001		Model 51-1732—400wv	Part of C47
C14	Condenser, filament by-pass, 100 $\mu$ f.	62-110001001	C48	Condenser, line filter, .01 $\mu$ f.	45-3505-41*
C15	Condenser, grid by-pass (Phono),		C49	Condenser, line filter, .01 $\mu$ f.	45-3505-41*
	1500 $\mu$ f.	62-215001001	I1	Pilot lamp	34-2065
C16	Condenser, d-c blocking, 47 $\mu$ f.	62-051009001*	J1	Socket, FM antenna	27-6214-1
C17	Condenser, cathode by-pass, 100 $\mu$ f.	62-110001001	J2	Socket, AM antenna	27-6252-9
C18	Condenser, trimmer (FM)	31-6511-10	J3	Socket, phono input	
C19	Condenser, temperature compensating,		J4	Jack, FM test	27-6180
	4.7 $\mu$ f.	30-1224-29	L1	Coil, FM aerial	32-4489
C20	Condenser, temperature compensating,		L2	Coil, FM r-f	32-4490
	7.5 $\mu$ f.	30-1224-65	L3	Coil, FM oscillator	32-4488
C21	Condenser, d-c blocking, phono coupling,		L4	Choke, plate load	32-4422-10
C22	Condenser, plate decoupling, 100 $\mu$ f.	62-110001001	L5	Choke, plate load	32-4422-10
C23	Condenser, plate decoupling, .01 $\mu$ f.	61-0120*	LA1	Loop aerial, Model 51-1731	32-4394-10
C24	Condenser, a-v-c by-pass, .01 $\mu$ f.	61-0120*		Model 51-1732	32-4394-11
C25	Condenser, filament by-pass, .01 $\mu$ f.	61-0120*	LA2	Aerial, FM line cord	41-3791-1
C26	Condenser, screen by-pass, .002 $\mu$ f.	61-0062*	LS1	Speaker, Model 51-1731	36-1626-5
C27	Condenser, plate decoupling, .006 $\mu$ f.	45-3500-7*		Model 51-1732	36-1610-6
C28	Condenser, by-pass, 100 $\mu$ f.	62-110001001	R1	Resistor, cathode bias, 120 ohms	66-1128340*
C29	Condenser, cathode by-pass, .01 $\mu$ f.	61-0120*	R2	Resistor, screen dropping, 27,000 ohms	66-3278340*
C30	Condenser, filament by-pass, .01 $\mu$ f.	61-0120*	R3	Resistor, plate decoupling, 1000 ohms	66-2108340*
C31	Condenser, screen by-pass, .002 $\mu$ f.	61-0062*	R4	Resistor, plate dropping (AM),	
C33	Condenser, plate decoupling, .01 $\mu$ f.	61-0120*		Model 51-1731—22,000 ohms	66-3228340*
C34	Condenser, i-f filter, 150 $\mu$ f.	60-10155407		Model 51-1732—47,000 ohms	66-3478340*
C35	Condenser, electrolytic, diode load filter,		R5	Resistor, plate dropping (FM),	
	2 $\mu$ f., 50v	30-2417-7		Model 51-1731—1000 ohms	66-2108340*
C36	Condenser, de-emphasis, .002 $\mu$ f.	61-0062*		Model 51-1732—10,000 ohms	66-3108340*
C37	Condenser, tone compensation,		R6	Resistor, plate load (Phono),	
	100 $\mu$ f.	62-110001001		27,000 ohms	66-3278340*
C38	Condenser, d-c blocking, .02 $\mu$ f.	61-0108*	R7	Resistor, plate decoupling (Phono),	
C39	Condenser, tone compensation,			33,000 ohms	66-3338340*
	Model 51-1731—.02 $\mu$ f.	61-0108*	R8	Resistor, grid return, 1 megohm	66-5108340*
	Model 51-1732—.03 $\mu$ f.	30-4517	R9	Resistor, parasitic suppressor,	
C40	Condenser, d-c blocking, .006 $\mu$ f.	45-3500-7*		Model 51-1731—680 ohms	66-1688340*
C41	Condenser, tone control, hi-cut, .006 $\mu$ f.	45-3500-7*		Model 51-1732—1000 ohms	66-2108340*
C42	Condenser, plate by-pass, 100 $\mu$ f.	62-110001001	R10	Resistor, grid return, 1 megohm	66-5108340*
C43	Condenser, d-c blocking, .006 $\mu$ f.	45-3500-7*	R11	Resistor, grid return, 15,000 ohms	66-3158340*
C44	Condenser, grid by-pass, parasitic suppression,		R12	Resistor, grid return, 330,000 ohms	66-4338340*
	51 $\mu$ f., Model 51-1732 only	62-051009001	R13	Resistor, parasitic suppressor,	
C45	Condenser, screen by-pass, parasitic suppression,			Model 51-1731—330 ohms	66-1338340*
	51 $\mu$ f., Model 51-1732 only	62-051009001		Model 51-1732—470 ohms	66-1478340*



ALL VOLTAGES MEASURED WITH A 2000-OHMS-PER-VOLT VOLTMETER BETWEEN POINTS INDICATED AND CHASSIS, AT A LINE VOLTAGE OF 117 V AC.  
 ALL RESISTOR VALUES IN OHMS AND ALL CONDENSER VALUES IN  $\mu$ LF UNLESS OTHERWISE MARKED.  
 \*PARTS VALUES AND VOLTAGES MARKED WITH AN ASTERISK APPLY TO MODEL 51-1732.  
 @ LESS THAN ONE OHM

Figure 4. Philco Radio-Phonograph Models 51-1731 and 51-1732, Schematic Diagram

## REPLACEMENT PARTS LIST (Cont.)

Reference Symbol	Description	Service Part No.	MISCELLANEOUS	
			Description	Service Part No.
R14	Resistor, cathode bias (phono), 6800 ohms	66-2688340*	Cabinet, Model 51-1731	10822
R15	Resistor, plate dropping, Model 51-1731—22,000 ohms	66-3228340*	Dial scale	54-5101
	Model 51-1732—33,000 ohms	66-3338340*	Domes (4)	45-6190
R16	Resistor, grid return, 1 megohm	66-5108340*	Door pull	76-6241
R17	Resistor, cathode bias, 47 ohms	66-0478340*	Knife hinge (2)	45-6036
R18	Resistor, screen dropping, Model 51-1731—22,000 ohms	66-3228340*	Lid support	76-6275
	Model 51-1732—10,000 ohms	66-3108340*	Spring	56-8510
R19	Resistor, plate decoupling, 2200 ohms	66-2228340*	Tapped stud (2)	56-6296
R20	Resistor, grid return, 1 megohm	66-5108340*	Cabinet, Model 51-1732	10824
R21	Resistor, cathode bias, 120 ohms	66-1128340*	Bullet catch (2)	45-6002
R22	Resistor, screen dropping, 15,000 ohms	66-3158340*	Dial scale	54-5102
R23	Resistor, plate decoupling, 1000 ohms	66-2108340*	Domes (4)	3363-2
R24	Resistor, a-v-c filter, 3.3 megohms	66-5338340*	Doors, matched set of 2	45-6621
R25	Resistor, i-f filter, 47,000 ohms	66-3478340*	Door pull (2)	56-7062
R26	Resistor, a-v-c voltage divider, 470,000 ohms	66-4478340*	Knife hinge, left hand (2)	56-8479
R27	Resistor, de-emphasis, 47,000 ohms	66-3478340*	Knife hinge, right hand (2)	56-8479-1
R28	Resistor, diode load (FM), 47,000 ohms	66-3478340*	Strike plate (2)	45-6003
R29	Resistor, base boost, Model 51-1731—27,000 ohms	66-3278340*	Cable and plug assembly, speaker and loop	41-3948-4
	Model 51-1732—18,000 ohms	66-3188340*	Changer mounting parts	
R30	Volume control	33-5535-27	Bumper (2)	55-0890
R31	Resistor, feed-back voltage divider, 4.7 ohms	66-9478340*	Clip, bottom mounting (4)	W2235-1FA9
R32	Tone control, 4 megohms	33-5566-12	Drive screws (8)	
R33	Resistor, inverse feedback, 120 ohms	66-1128340*	Frame	76-6257
R34	Resistor, grid return, 10 megohms	66-6108340*	Knob, pull	56-8496
R35	Resistor, plate load, 470,000 ohms	66-4478340*	Screw, knob mounting	1W10078FA3
R36	Resistor, grid return, 470,000 ohms	66-4478340*	Rail assembly, LH	76-6258
R37	Resistor, inverse feedback, 2.7 megohms	66-5278340*	Rail assembly, RH	76-6259
R38	Resistor, cathode bias, Model 51-1731—120 ohms, 1w	66-1124340*	Sleeve, rubber (3)	54-7798
	Model 51-1732—180 ohms, 1w	66-1184340*	Speed nut (3)	
R39	Resistor, parasitic suppressor, 10 ohms, Model 51-1732 only	66-0108340*	Spring, changer mounting (3), top (heavy)	
R40	Resistor, bleeder, Model 51-1731—22,000 ohms	66-3225340*	Spring, changer mounting (3), bottom (light)	56-7059-1FCP
	Model 51-1732—120,000 ohms	66-4125340*	Clip, pilot lamp socket mounting	56-3545FA3
R41	Resistor, filter, Model 51-1731—3300 ohms, 2w	66-2335340*	Diffusing panel	54-8171-1
	Model 51-1732—2500 ohms, 2w	33-1335-93	Spring, diffusing panel mounting	56-3587-1
R42	Resistor, filter, 330 ohms, 7w	33-1335-90	Drive cord, 25 foot reel	45-8750*
S1	Switch, off-on	Part of R32	Frame assembly, changer mounting	76-6264
T1	Transformer, aerial, AM	32-4413-1	Knob (3)	54-4718-6
T2	Transformer, oscillator, AM, Model 51-1731	32-4458-2	Knob, with brown dot	54-4718-12
	Model 51-1732	32-4458-3	Pointer	56-5630-29
T3	Transformer, output, Model 51-1731	32-8460-1	Spring, gang and pointer drive (2)	56-3167
	Model 51-1732	32-8407	Pointer rail assembly, backplate	76-6195
T4	Transformer, power, Model 51-1731	32-8459	Rubber band, scale mounting (2)	54-4480
	Model 51-1732	32-8462	Rubber mounts, gang (5)	27-4771-1
W1	Line cord	L-2183*	Scale strap	56-4756FE11
WS	Wafar switch	42-1942	Scale straps (2)	56-2234-2
Z1	Transformer, 1st FM	32-4372A	Socket, Loktal, 5AZ4	27-6207
Z2	Transformer, 1st AM	32-4258-3A	Socket, Loktal, 7F8	27-6207-1
Z3	Transformer, 2nd FM	32-4372-2A	Socket, 7-pin miniature (3)	27-6265-1
Z4	Transformer, 3rd FM	32-4310-3A	Socket, 9-pin miniature	27-6203-5
Z5	Transformer, 2nd AM	32-4240-3A	Socket, octal	27-6174
			Socket, pilot lamp	27-6233-16
			Speaker bolts (4)	W700-2
			Tuning shaft	56-8429
			Bushing	27-9437
			Spring, hairpin	57-1468FA3
			Washer, fibre, speaker mounting (4)	27-7467

## AM ALIGNMENT PROCEDURE

Make alignment with loop aerial connected to radio. The AM alignment should be made before the FM alignment.

**DIAL POINTER:** Calibration and pointer-index measurements are shown in figure 3. With tuning gang fully meshed, set pointer to index mark.

**OUTPUT METER:** Connect across speaker voice-coil terminals.

**SIGNAL GENERATOR:** Connect AM r-f signal generator as indicated in chart. Generator ground lead to chassis. Use modulated output.

**RADIO CONTROLS:** Set volume control to maximum, tone control counterclockwise, and band switch to broadcast position.

**OUTPUT LEVEL:** During alignment, adjust signal-generator output to hold output meter indication below 1.25 volts.

## AM ALIGNMENT CHART

STEP	SIGNAL GENERATOR		RADIO		ADJUST TRIMMER
	CONNECTION TO RADIO	DIAL SETTING	DIAL SETTING	SPECIAL INSTRUCTIONS	
1	Through a .01- $\mu$ f. condenser to mixer grid, pin 1, of 7F8/S.	455 kc.	Gang fully meshed.	Adjust, in order given, for maximum output.	TC11—2nd AM i-f sec. TC10—2nd AM i-f pri. TC5—1st AM i-f sec. TC4—1st AM i-f pri.
2	Radiating loop. (See Note below.)	1600 kc.	1600 kc.	Adjust for maximum output.	C1D—AM osc. shunt
3	Same as step 2.	1500 kc.	1500 kc.	Adjust for maximum output.	C1B—AM ant. shunt
4	Same as step 2.	580 kc.	580 kc.	Adjust for maximum output. This should not be necessary unless T1 (aerial transformer) has been replaced.	TC1—AM ant. tuning core

**RADIATING LOOP:** Make up a 6-to-8 turn, 6-inch-diameter loop, using insulated wire; connect to signal generator leads and place near radio loop aerial.

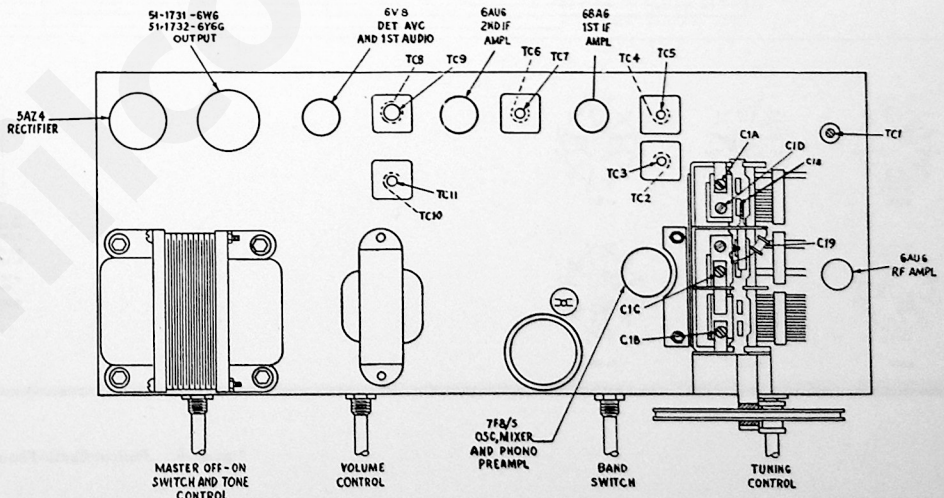

Figure 5. Top View, Showing Trimmer Locations

## FM ALIGNMENT PROCEDURE

Make the AM alignment first.

**RADIO CONTROLS:** Set volume control to maximum, tone control counterclockwise, and band switch to FM position. Allow radio and signal generator to warm up for at least 15 minutes before making alignment.

**SIGNAL GENERATOR:** Use a signal generator capable of delivering a 9.1-mc. FM signal with a deviation of  $\pm 80$  kc., and modulated AM signals of 92 mc., 105 mc., and 108 mc. Philco Model 7008 Precision Visual Alignment Generator fulfills these requirements. **NOTE:** The signal generator must be well bonded to radio chassis.

**OSCILLOSCOPE:** Connect to FM Test jack. Model 7008 is suggested.

**OUTPUT METER:** Connect across speaker voice-coil terminals.

**R-F COIL NOTE:** Check resonance of circuits containing coils L1, L2, and L3 by inserting each end of a tuning wand, such as Philco Part No. 45-8885, into coil. If signal strength increases when powdered-iron end is inserted, compress turns slightly. If signal strength increases when brass end is inserted, spread turns slightly. If signal strength decreases when each end is inserted, no adjustment is necessary. Do no spread or compress turns excessively; only a small change is required at these high frequencies.

### FM ALIGNMENT CHART

STEP	SIGNAL GENERATOR		RADIO		ADJUST TRIMMER
	CONNECTION TO RADIO	DIAL SETTING	DIAL SETTING	SPECIAL INSTRUCTIONS	
1	Through a .01- $\mu$ f. condenser to pin 1 of 6AU6 I-F amplifier.*	9.1 mc. $\pm 80$ kc. deviation.	Gang fully meshed.	Adjust TC9 for correct crossover. Adjust TC8 for maximum and equal peaks. Repeat.	TC9—FM det. sec. TC8—FM det. pri.
2	.01- $\mu$ f. condenser to pin 1 of 6BA6.*	9.1 mc. $\pm 80$ kc. deviation.	Gang fully meshed.	Adjust, in order given, for maximum and equal peaks. Repeat.	TC7—FM 2nd i-f sec. TC6—FM 2nd i-f pri.
3	.01- $\mu$ f. condenser to pin 1 of 7F8/S.*	9.1 mc. $\pm 80$ kc. deviation.	Gang fully meshed.	Adjust, in order given, for maximum and equal peaks. Repeat.	TC3—FM 1st i-f sec. TC2—FM 1st i-f pri.
4	Through a 300 ohm dummy aerial to FM aerial socket, J1.	108 mc.	108 mc.	Adjust trimmer for maximum reading on output meter.	C18—FM osc.
5	Same as step 4.	105 mc.	105 mc.	Adjust for maximum output while rocking gang.	C1C—FM r-f C1A—FM aerial
6	Same as step 4.	92 mc.	92 mc.	Adjust coils, in order given, for proper resonance (see R-F COIL NOTE).	L3—FM osc. coil L2—FM r-f coil L1—FM aerial coil

\*CAUTION: Do not overload! When aligning the i-f stages, the curve will be distorted or destroyed if too great a signal is used. To check, attenuate the signal input. If the curve changes in form, rather than merely decreasing in amplitude, the stage is overloaded.

### CORRECTIONS TO PARTS LIST

Reference Symbol	Description	Service Part No.
C10	Condenser, neutralization, 3.3 $\mu$ fd. ....	30-1224-49
C21	Condenser, d-c blocking, phono coupling	
	Model 51-1731, .001 $\mu$ d. ....	45-3505-52
	Model 51-1732, .0033 $\mu$ d. ....	45-3505-55
J3	Socket, phono input .....	27-6252
	Drive screw (8) .....	1W19432FA3
	Knob, pull .....	56-8496
	Speed nut (3) .....	W-2554FA33
	Spring (3), changer mtg. bottom (light) .....	56-7059-1FJ47

### PRODUCTION CHANGE

#### Run 2

Condenser C19, 4.7  $\mu$ fd., Part No. 30-1224-29, was removed.